



S, SV, SVi, NGF, & quickdraw™ Beverage/Ice Dispensers

Installation, Use & Care Manual

This manual is updated as new information and models are released.
Visit our website for the latest manual. www.manitowocfsg.com

Section 1

General Information

Read This Manual

Manitowoc Beverage Equipment (MBE) developed this manual as a reference guide for the owner/operator and installer of this equipment. Please read this manual before installation or operation of the machine. A qualified service technician must perform installation and start-up of this equipment, consult **Section 5** within this manual for service assistance.

If you cannot correct the service problem, call your MBE Service Agent or Distributor. Always have your model and serial number available when you call.

Your Service Agent _____

Service Agent Telephone Number _____

Your Local MBE Distributor _____

Distributor Telephone Number _____

Model Number _____

Serial Number _____

Installation Date _____

Unit Inspection

Thoroughly inspect the unit upon delivery. Immediately report any damage that occurred during transportation to the delivery carrier. Request a written inspection report from a claims inspector to document any necessary claim.



Warning

PERSONAL INJURY POTENTIAL

Do not operate equipment that has been misused, abused, neglected, damaged, or altered/modified from that of original manufactured specifications.

Model Numbers

This manual covers the following models:

Beverage/Ice Dispensers
S-150, S-200, S-250, SV-150, SV-175, SV-200, SV-250, SV-150i, SV-175i, SV-200i, SV-250i, SV-250QD, NGF-250, NGF-250QD

How to Read a Model Number

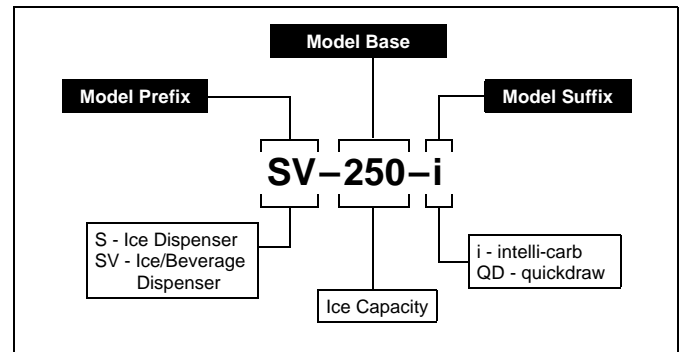

Accessories

BAFFLE FOR MANITOWOC® ICE MACHINES

When installing a Manitowoc Ice Machine on a dispenser, a baffle kit is required for proper installation. The baffle kit is designed to prevent ice from lying against the front of the ice machine, and melting down the front of the dispenser. There are two different baffle kits available for "S" series ice machines, one kit is for the 30" wide machine, and the other kit is for the 22" wide machine. There is also a kit for "Q" series ice machines.

Kits are available through your local distributor. List prices may be subject to change without notification. Please call your local parts distributor for current pricing before ordering.

NOTE: For full information about ice machine installation, including plumbing lines connections and electrical requirements, see the ice machine installation manual.

MANUAL FILL LID FOR DISPENSERS WITH AN ICE MACHINE

If you are top mounting your dispenser with an ice machine, you will require a lid for the manual fill area at the top, front of the dispenser.

If you ordered a dispenser and an ice machine at the same time, the manual fill lid was included with the unit. The manual fill lid can be ordered from your local distributor.

ICE FLOW RESTRICTOR

An optional ice flow restrictor decreases the amount of ice allowed to enter the ice chute by blocking a small area at the entrance of the dispenser chute. This in turn restricts the flow of ice that is dispensed into your cup.

Please refer to the instructions included in kit #5013822 for more information on how to install.



Ice Flow Restrictor

LEGS

Legs are optional equipment with most MBE dispensers. Standard legs are 4" (10.2 cm) tall stainless steel legs. If an ice machine is installed on top of the dispenser, legs must not be installed. We do not recommend using legs when an ice machine is mounted on the dispenser. The combined weight of the dispenser, ice and ice machine is more evenly distributed when the base area of the dispenser is in contact with the countertop.

Serial Number Location

This number is required when requesting information from your local distributor. The serial number is listed on the SERIAL NUMBER DECAL affixed to the dispenser.

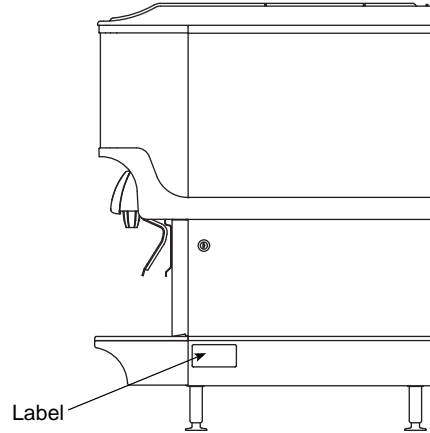

Serial Number Location

Warranty Information

Consult your local MBE Distributor for terms and conditions of your warranty. Your warranty specifically excludes all beverage valve brixing, general adjustments, cleaning, accessories and related servicing.

Your warranty card must be returned to MBE to activate the warranty on this equipment. If a warranty card is not returned, the warranty period can begin when the equipment leaves the MBE factory.

No equipment may be returned to MBE without a written Return Materials Authorization (RMA). Equipment returned without an RMA will be refused at MBE's dock and returned to the sender at the sender's expense.

Please contact your local MBE distributor for return procedures.

Section 2 Installation Instructions

General

These instructions are provided to assist the qualified installer. Contact your Manitowoc Beverage Equipment Service Agent or call Manitowoc Beverage Equipment for information regarding start-up services.

Important

Failure to follow these installation guidelines may affect warranty coverage.

Dimensions

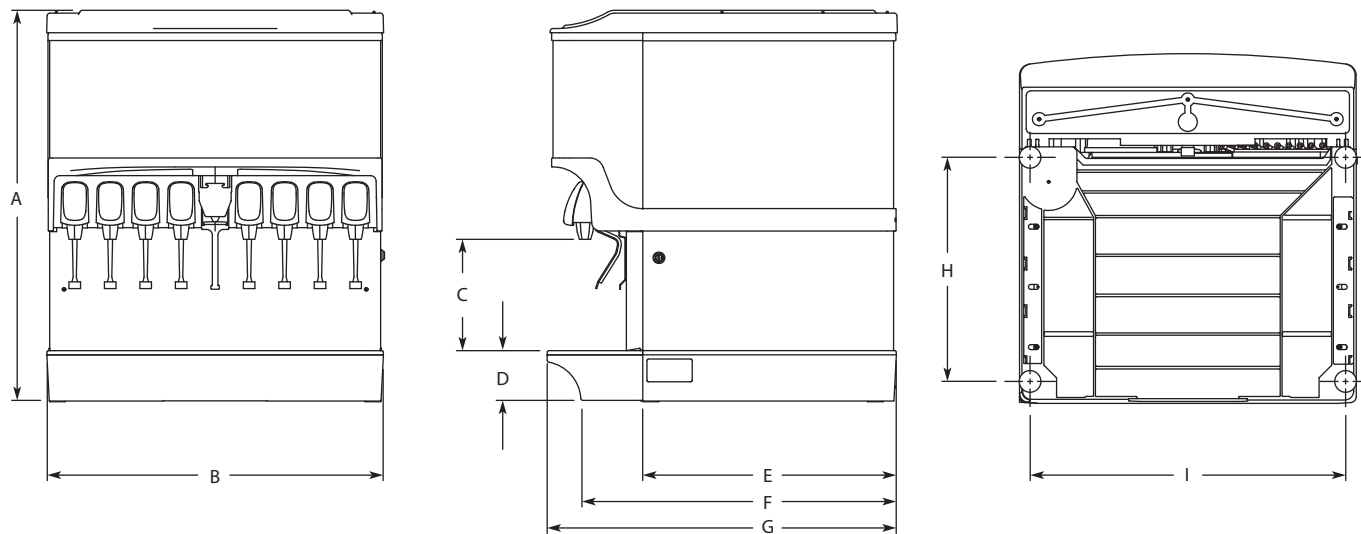

Model/Ice Capacity	A	B	C	D	E	F	G	H	I
S/SV-150	34.81" (88.4 cm)	23.00" (58.4 cm)	9.94" (17.6 cm)	4.44" (11.3 cm)	22.63" (57.5 cm)	28.00" (71.1 cm)	31.13" (79.1 cm)	20.00" (50.8 cm)	20.44" (51.9 cm)
S/SV-175	34.81" (88.4 cm)	25.00" (63.5 cm)	9.94" (17.6 cm)	4.44" (11.3 cm)	22.63" (57.5 cm)	28.00" (71.1 cm)	31.13" (79.1 cm)	20.00" (50.8 cm)	22.44" (57.0 cm)
S/SV-200	34.81" (88.4 cm)	30.00" (76.2 cm)	9.94" (17.6 cm)	4.44" (11.3 cm)	22.63" (57.5 cm)	28.00" (71.1 cm)	31.13" (79.1 cm)	20.00" (50.8 cm)	27.44" (69.7 cm)
S/SV/NGF-250	39.81" (101.1 cm)	30.00" (76.2 cm)	9.94" (17.6 cm)	4.44" (11.3 cm)	22.63" (57.5 cm)	28.00" (71.1 cm)	31.13" (79.1 cm)	20.00" (50.8 cm)	27.44" (69.7 cm)
S/SV/NGF-250QD	39.88" (101.3 cm)	30.00" (76.2 cm)	9.94" (17.6 cm)	4.44" (11.3 cm)	22.63" (57.5 cm)	28.00" (71.1 cm)	31.13" (79.1 cm)	20.00" (50.8 cm)	27.44" (69.7 cm)

Footprints

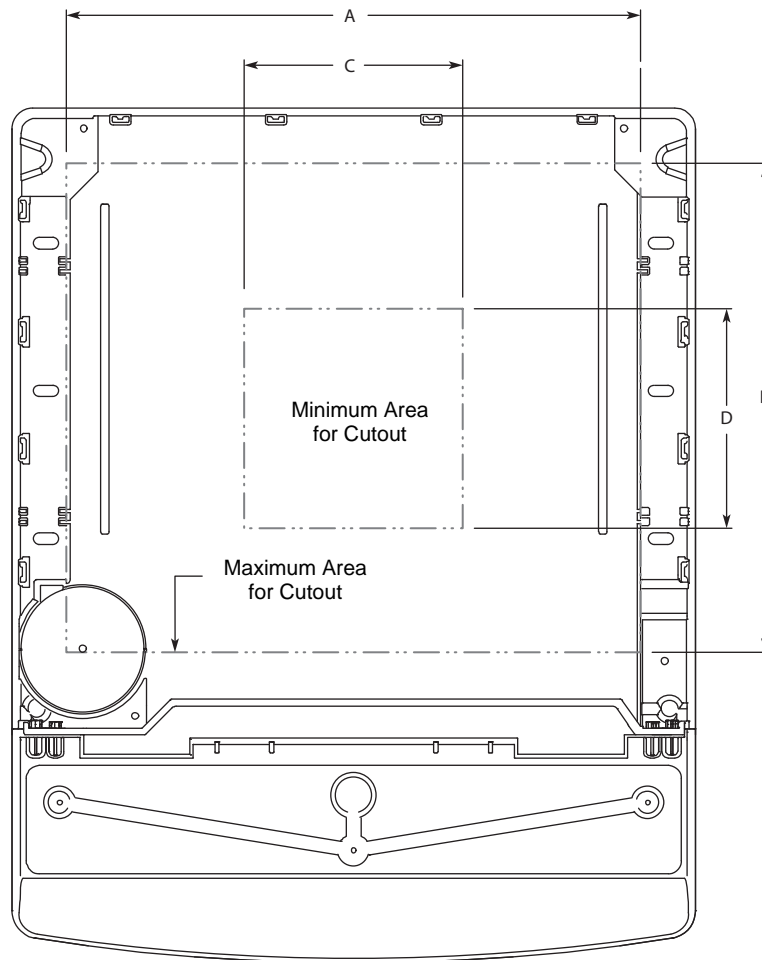

NOTE: Footprint for S/SV-175 shown.

S & SV	Maximum		Minimum	
	A	B	C	D
150	19.00" (48.3 cm)	17.81" (45.2 cm)	8.00" (20.3 cm)	8.00" (20.3 cm)
175	21.00" (53.3 cm)	17.81" (45.2 cm)	8.00" (20.3 cm)	8.00" (20.3 cm)
200	26.00" (66.0 cm)	17.81" (45.2 cm)	8.00" (20.3 cm)	8.00" (20.3 cm)
250*	26.00" (66.0 cm)	17.81" (45.2 cm)	8.00" (20.3 cm)	8.00" (20.3 cm)
250QD*	26.00" (66.0 cm)	17.81" (45.2 cm)	8.00" (20.3 cm)	8.00" (20.3 cm)

* Includes NGF

Warning

Cutting the countertop may decrease its strength. Counter must be braced to support the dispenser countertop weight plus ice storage capacity and weight of ice machine, if applicable.